

The Australian water balance model

Walter Boughton*

Griffith University, Brisbane, Australia

Received 25 March 2003; received in revised form 18 August 2003; accepted 22 October 2003

Abstract

The Australian water balance model (AWBM) is a catchment water balance model that calculates runoff from rainfall at daily or hourly time increments. The daily version is used for water yield and water management studies; the hourly version is used for design flood estimation. This paper describes the origin and development of the AWBM beginning with elementary modelling components of saturation overland flow. A particular feature of the AWBM is the development of model-specific calibration procedures based on the model structure, including a graphical analysis of rainfall and runoff data, multiple linear regression and an automatic self-calibrating procedure. Application of the model for daily streamflow simulation is illustrated using data from 19 catchments located across Australia. Application at hourly time steps for design flood estimation is demonstrated on three catchments in Victoria. A procedure for use of the model to estimate daily streamflows on ungauged catchments is illustrated using the 19 catchments from the water yield study. Applications of the model in several research programs are described.

© 2003 Elsevier Ltd. All rights reserved.

Keywords: AWBM; Hydrological modelling; Rainfall–runoff models; Design flood estimation

Software Availability

Program title: AWBM
Developer: Dr. W. Boughton
Contact address: 11 Preston Place, Brookfield, Qld. 4069, Australia
First available: original AWBM-1993; latest AWBM 2002–2002
Hardware: PC
Source language: Borland Turbo Pascal 6.0
Program size: 66 KB
Cost: Free
Availability: website <http://www.catchment.crc.org.au/models>
System title: Continuous simulation system for design flood estimation (CSS) (AWBM is the main water balance component)
Developer: Dr. W. Boughton

Contact address: 11 Preston Place, Brookfield, Qld. 4069, Australia
First available: 1999
Hardware: PC
Source language: Borland Turbo Pascal 6.0
System size: 14 programs 700 KB total
Cost: Free
Availability: website <http://www.catchment.crc.org.au/models>

1. Introduction

The Australian water balance model (AWBM) was developed in the early 1990s (Boughton, 1993a; Boughton and Carroll, 1993) and is now one of the most widely used rainfall–runoff models in Australia. There are two main versions; one for daily water yield and low flow studies, the other for continuous simulation of flood runoff at hourly time steps. A version of the daily water yield model for use on ungauged catchments was released at the beginning of 2003.

* Address: 11 Preston Place, Brookfield, Qld., Australia. Tel.: +61-7-3374-3718; fax: +61-7-3374-3718.

E-mail address: walterboughton@bigpond.com (W. Boughton).

Each of the versions of the AWBM is integrated into a suite of programs that provide for data checking, streamflow partitioning for evaluation of baseflow parameters, calibration of parameters, stochastic daily rainfall generation, daily to hourly disaggregation of generated rainfalls, and generation of long sequences of daily streamflows (for water yield studies) or hourly runoff (for flood studies). The software and operating manuals (Boughton, 2001; 2002) are freely available for downloading from the web site of the Cooperative Research Centre for Catchment Hydrology (CRCCH) at <http://www.catchment.crc.org.au/models>.

This paper reviews the development of the model and explains its structure. In the terminology of Wheatter et al. (1993) the model is a conceptual model, and is developed from concepts of saturation overland flow generation of runoff. A significant feature of the AWBM is the development of calibration procedures that are specific to the model and are based on the model structure, rather than the more common approach of trial and error testing of sets of parameter values. The calibration procedures and their development are described in Section 3. Results are presented from use of the AWBM for modelling water yield (Section 4), design flood estimation (Section 5), and for estimating the water yield of ungauged catchments (Section 6). Some comparative studies with other models are given in Section 7.

2. Development of the AWBM

2.1. Generation of runoff

Saturation overland flow is the excess rainfall remaining after the surface storage capacity of a catchment has been replenished. Thus the amount of abstraction of rainfall depends on the antecedent moisture conditions of the catchment. It should be stressed that there can be spatial variability in the abstraction and the generation of runoff over the catchment. For modelling purposes, it is possible to start from very simple concepts of catchment behaviour and gradually introduce such variables as antecedent wetness and spatial variability of the abstractions in order to develop a structure for modelling the rainfall–runoff relationship.

2.1.1. The single bucket model

The simplest model of abstractions of rainfall over a catchment is the elementary bucket model shown in Fig. 1a. The capacity C of the bucket represents the surface storage capacity of the catchment and is expressed in units of depth (in. or mm). This is the conceptual basis of the antecedent precipitation index (API) model (Kohler and Linsley, 1951) used for flood forecasting. The behaviour of the model is based on

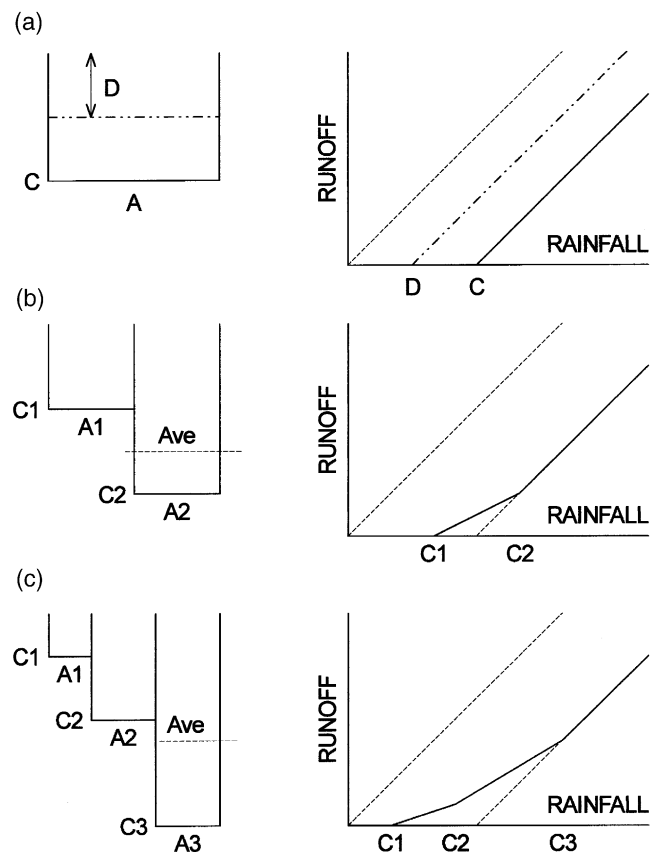

Fig. 1. Relation of runoff to rainfall with variability in surface storage.

the assumption that all rainfall is abstracted and no runoff occurs until the bucket is filled, following which all rainfall becomes runoff. If the bucket is empty at the start of the rainfall, i.e. zero antecedent wetness, then the relationship between the rainfall and the runoff is shown at right in Fig. 1a—line C. The units of both rainfall and runoff are units of depth (in. or mm).

If there was antecedent wetness at the start of rainfall, then the abstraction of rainfall is the amount required to fill the bucket, illustrated by the deficit D . The effect of antecedent wetness is to move the rainfall–runoff relationship to the left, shown at right in Fig. 1a as the move of the relationship from C to D . In the limiting case, when the catchment was saturated by prior rain, i.e. D is zero, then all rainfall becomes runoff, and the rainfall–runoff relationship is the 45° line from the origin.

2.1.2. Multi-capacity models

The effect of spatial variability in surface storage capacity is demonstrated in Fig. 1b by considering a catchment with two capacities, C_1 and C_2 covering partial areas A_1 and A_2 , respectively of the catchment. The partial areas are fractions of the catchment, i.e. $A_1 + A_2 = 1.0$. Runoff begins after an amount of rainfall that is sufficient to fill the smaller storage capacity C_1 .

Until the rainfall is sufficient to fill the larger capacity C_2 , the rainfall–runoff relationship from the smaller store will be a line with slope A_1 vertical to 1.0 horizontal. When the rainfall is enough to fill both stores, then all further rain becomes runoff and the rainfall–runoff relationship is again a 45° line. If that 45° is extended backwards, it intersects the x -axis at the average storage capacity, i.e. at $Ave = C_1 * A_1 + C_2 * A_2$.

As the catchment is further divided into more partial areas of different capacity, the rainfall–runoff relationship becomes more like a smooth curve. In Fig. 1c, there are three areas of different surface storage capacity. Assuming zero antecedent moisture, runoff commences after an amount equal to the smallest capacity C_1 , and the rainfall–runoff relationship becomes a 45° line after an amount equal to the largest capacity C_3 . If the 45° line is projected backwards, it intersects the x -axis at a value of the average surface storage capacity.

The shape of the rainfall–runoff relationship shown in Fig. 1c is well known. Examples of such relationships are shown in many hydrology textbooks. The most well known curves of this shape occur in the USDA SCS curve number method of estimating runoff from rainfall, although the reasoning behind the curve number method is quite different to that given above (Rallison, 1980). In a manner similar to Fig. 1a, the curve number method uses curves closer to the origin to represent higher antecedent conditions and those further away to represent lower antecedent conditions.

The concept of multi-capacity moisture accounting for estimating runoff is not new. Kohler and Richards (1962) arbitrarily selected capacities of 2, 5, 10 and 20 in. as partial areas of surface storage capacity and, for each storm, calculated a weighted index of basin moisture deficiency that was used with precipitation to estimate runoff by graphical correlation. The multi-capacity accounting was used only to estimate a weighted index of moisture deficiency, and no consideration was given to partial areas of runoff or saturation overland flow.

On larger catchments, there is a need to attenuate the arrival at the catchment outlet of the generated runoff in order to reproduce the spread of arrival times that occur on a natural catchment. For daily water balance modelling, this can be achieved by directing the rainfall excess through a simple store and adjusting the discharge from the store to match the recession characteristics of the recorded streamflow. Fig. 2 shows a surface runoff attenuation store of the type used in practice.

2.2. Baseflow recharge and discharge

Figs. 1 and 2 have an implied assumption that all runoff is surface runoff, and there is no provision for

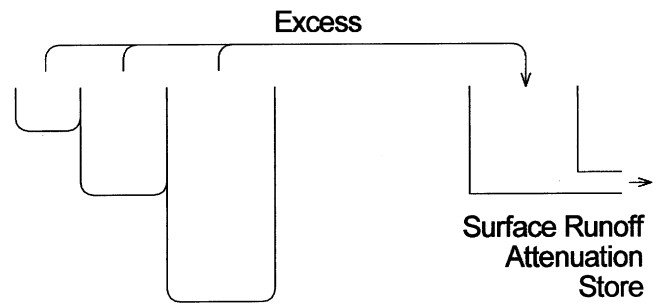

Fig. 2. Surface runoff attenuation store.

baseflow. While baseflow is absent in runoff on some catchments, it is an important component of runoff in many catchments of interest. This section deals with the background to modelling baseflow, particularly in the structure of the AWBM.

Baseflow is usually modelled as the drainage from a single store. The recession of baseflow is commonly linear when the logarithm of flow is plotted against time, implying that baseflow on any day is a fixed fraction K_b of flow on the previous day. The fixed fraction K_b is called the “recession constant”. The fraction $(1.0 - K_b)$ is the amount of water in the baseflow store that is discharged at each time step.

Many early models provided for recharge of baseflow storage by drainage from the surface moisture stores. During the development of the AWBM, such an arrangement was tried and reported (Boughton, 1987). Other models such as the Probability Distributed Model (Moore, 1985) and the Probability Distributed Soil Moisture Model (Muncaster et al., 1997) use this approach (see Section 2.4). Fig. 3a shows the

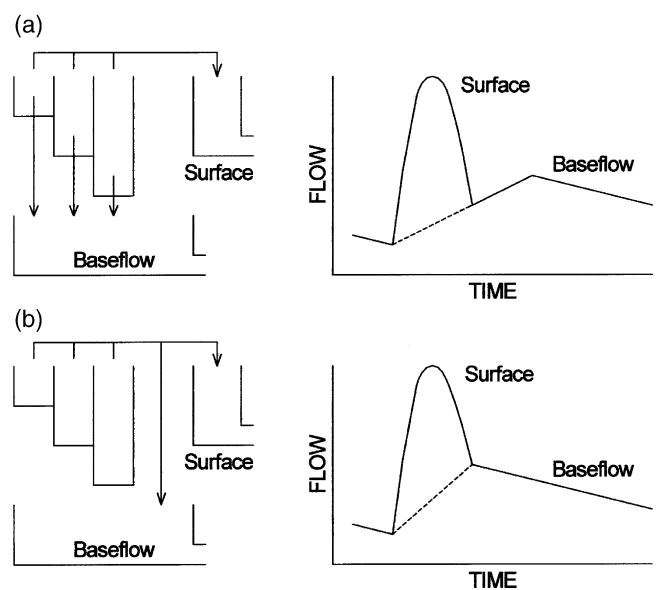

Fig. 3. Model structures for baseflow recharge and resulting streamflow.

consequences on modelled streamflows of using this model structure. The drainage rate from surface storage must be slow enough that the surface stores simulate slow drying. The consequence is that the baseflow store continues to be recharged long after surface runoff from heavy rain has ceased, and the baseflow discharge into streamflow continues to increase for the same period. The pattern of modelled streamflows, shown in Fig. 3a, is obviously different to observed streamflows.

The alternate model structure is to transfer a fraction of the generated runoff direct to the baseflow store at the same time as the residual is transferred to the surface attenuation store. This model structure is shown in Fig. 3b. This latter structure makes the modelled streamflow accord with observed streamflows in which the baseflow discharge is a maximum at the end of surface runoff and recedes afterwards. This is the structure adopted in the AWBM. There is similarity with the division of flow components in other models; e.g. the division of total flow into quickflow and slowflow in the IHACRES model (Evans and Jakeman, 1998).

2.3. AWBM

The structure of the AWBM, shown in Fig. 4, is based on the reasoning described in Sections 2.1 and 2.2. The model is operated at either daily or hourly time steps. At each time step, rainfall is added to each of the surface stores and evapotranspiration is subtracted. If there is any excess from any store, it becomes runoff and is divided between surface runoff and baseflow. The baseflow index (BFI) is the fraction of total flow that appears as baseflow. This parameter can be determined from a streamflow record by using

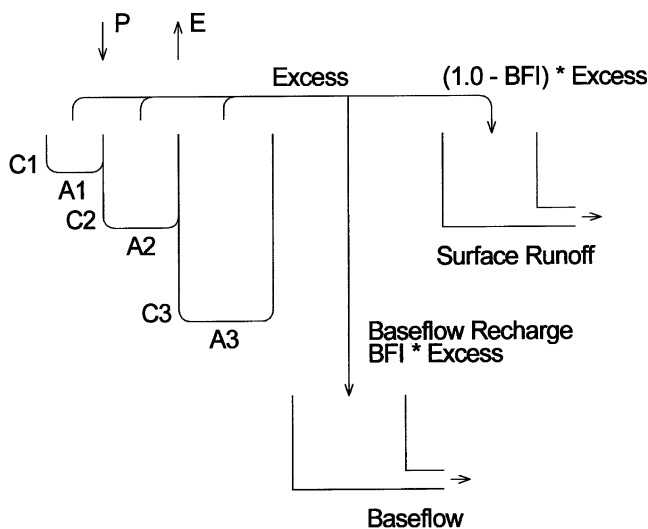

Fig. 4. Structure of the AWBM.

any of the established techniques for partitioning of flow (Chapman, 1999).

The use of three surface stores instead of two or four is a pragmatic choice. The more partial areas and surface storage capacities that are used, then the better is the fit to rainfall and runoff data, but the increase in number of parameters lessens the reliability in the calibration of each parameter. More parameters produce more interactions among parameters and less definition of each. Three partial areas and capacities provide enough flexibility to fit to rainfall and runoff data but the parameters are few enough to permit positive calibration (Section 3).

The surface attenuation store is used when the calculations are in daily time steps. Discharge from the store is calculated as $SS * (1.0 - K_s)$ where SS is the amount of moisture in the store and K_s is the recession constant of surface runoff for the time step of the calculations. The recession constant can be determined directly from the streamflow record (Klaassen and Pilgrim, 1975). This component of the model is replaced by an hourly flood hydrograph model when the flows are modelled at hourly time steps. The use of different flood hydrograph models for design flood estimation is briefly described in Section 5.

Discharge from the baseflow store is calculated as $BS * (1.0 - K_b)$ where BS is the amount of moisture in the store and K_b is the baseflow recession constant for the time step of the calculations. The baseflow recession constant can also be determined directly from the streamflow record.

2.4. Models with similar structures

There are at least three rainfall–runoff models with structures that have some similarity to the AWBM—the USDA SCS curve number method, the PDM of Moore (1985), and the modification of that model, the PDSMM (Muncaster, 1998).

Using the principles set out in Section 2.1 and Fig. 1, the curves of the curve number method can be interpreted as a pattern of surface storage capacity (Boughton, 1989; Steenhuis et al., 1995). All of the curves have the same proportions relative to the initial abstraction I_a , as shown in Fig. 5. The pattern has an upper limit of infinity, implying that some portion of every catchment never produces runoff. This is one weakness of the method, i.e. runoff is usually underestimated in big runoff events, and this is compensated for in calibration by overestimation in small to medium events. The other drawback of the method is that there is no provision for baseflow, which severely limits the range of catchments to which it can be applied.

The PDM and the PDSMM are variations of the same model. The description given here is of the PDSMM version. Like the curve number method, the PDSMM

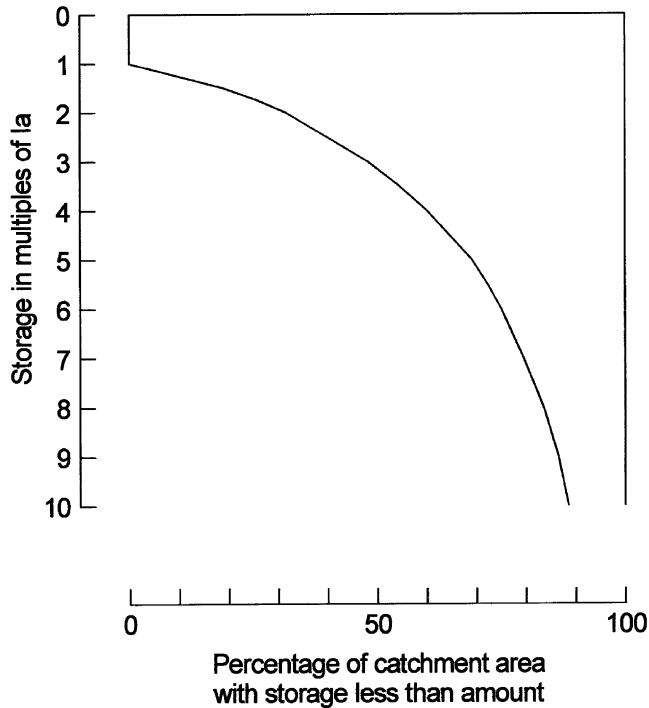

Fig. 5. Surface storage pattern of the USDA SCS CN curves.

has a preset curvilinear pattern of surface storage capacity with a lower limit of zero and a finite upper limit (see Fig. 6). The lower limit of zero capacity will produce too many small runoff events in regions other than those of constant wetness. The drainage from surface storage for recharge of baseflow storage produces problems in calculated streamflow as shown in Fig. 3a.

The curvilinear patterns of surface storage can be fitted with two parameters (a maximum storage capacity and a shape parameter) and might be intuitively attractive in preference to the discrete capacities and

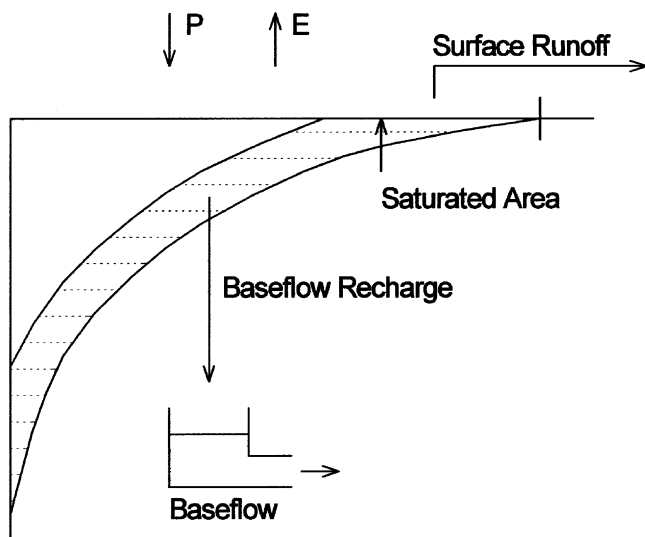

Fig. 6. Structure of the PDSMM.

partial areas of the AWBM. There are opposing views. The discrete parameters of the AWBM can be directly calibrated without trial and error testing (Section 3) whereas there are no such methods currently available for the curvilinear patterns.

3. Parameter determination

A significant feature of the AWBM has been the development of calibration procedures based on the structure of the model, rather than using trial and error testing of different sets of parameter values. The parameters to be determined are the surface storage capacities and their partial areas, and two baseflow parameters. The following describes the model-specific calibration procedures in approximately the chronological order of their development.

3.1. Graphical analysis of surface storage capacities and partial areas

The connection between model structure and the rainfall–runoff relationship, shown in Fig. 1c, can be used to deduce the surface storage capacities and their partial areas from a set of rainfall and runoff data. The following description is mainly taken from Boughton (1987).

The method is based on selecting storm totals of rainfall and runoff that occur at the end of dry periods that are long and dry enough to eliminate or minimize the effect of antecedent moisture. The rainfall data must be adjusted to allow for the effects of evaporation during the storm. When a storm extends over several days, evaporation loss can be significant. Therefore, the storm totals of rainfall are adjusted to allow for evaporation loss using the same procedure that is used in the AWBM. Fig. 7a shows a rainfall–runoff relationship from minimum antecedent moisture runoff events, and the values for capacities and partial areas of the surface storages that can be deduced from the components of the relationship.

Fig. 7b shows rainfall and runoff data from the 16.8 ha catchment on the Brigalow Research Station, about 400 km northwest of Brisbane. The average annual rainfall is 670 mm and the average annual runoff is 35 mm. Runoff is ephemeral and is wholly surface runoff, i.e. no baseflow. Only a few runoff events occur each year and antecedent moisture is very low for most events. The data show that there is a minimum surface storage capacity of about 60 mm, i.e. no runoff occurs for effective rainfall less than 60 mm. Above this threshold value, runoff is about 15% of the excess of effective rainfall above the threshold. This implies that runoff is occurring from about 0.15 of the catchment area for most of the small events that follow dry periods.

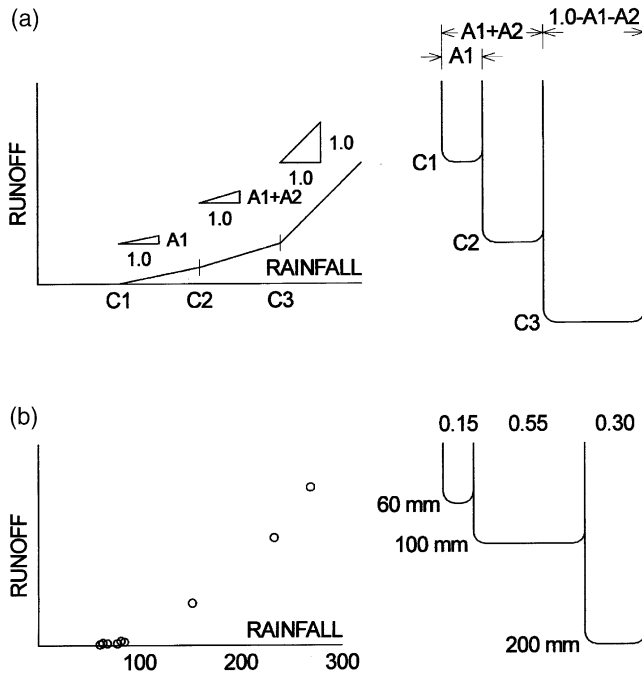

Fig. 7. Derivation of capacities and partial areas of surface storages from rainfall and runoff data.

The evaluation of the storage capacities of the remaining 85% cannot be conclusive because of the few data points that are available. A number of different combinations of capacity and area covered could be made to fit the available data, and the AWBM would calculate equally good results from each. In order to indicate the relative imprecision, rounded values of 100 and 200 mm occupying 0.55 and 0.30, respectively of the catchment were selected. This gives the model of the catchment shown at left in Fig. 7b.

The data from the 16.8 ha catchment on the Brigalow Research Station are wholly surface runoff. When baseflow is present in the runoff, the data must be processed to associate each part of the baseflow discharge with the rainfall that caused it. The following procedure is used. A streamflow partitioning method (Chapman, 1999) is used to separate surface runoff and baseflow. The fraction of the total flow occurring as baseflow (BFI) is found, and the amount of each surface runoff event is increased by $1.0/(1.0 - \text{BFI})$ to allow for the amount of recharge of baseflow storage that occurred at the time of the surface runoff. The adjusted volumes of surface runoff are then used in the same manner as before.

The graphical method is attractive because of its visual nature. It shows the number of data points contributing to each parameter value and gives better feeling for the goodness-of-fit than any wholly mathematical procedure. The disadvantages are the need for selection of runoff events with low antecedent catch-

ment moisture, the difficulty in dealing with baseflow in the runoff, and the manual labour in plotting and analysis. The method was converted to an arithmetic procedure (Boughton, 1990), but both approaches were replaced by a multiple linear regression procedure, as in the following section.

3.2. Multiple linear regression

The difficulties of selecting runoff events with low antecedent moisture and dealing with baseflow can be completely eliminated by using a multiple linear regression method of calibration. The description given here is taken mainly from Boughton (1993b). We wish to find the set of capacities (C_1 , C_2 , and C_3) and their partial areas (A_1 , A_2 , and A_3) whose combined excess most closely match the actual runoff values, usually monthly runoff values. This can be expressed as a multiple linear equation as follows:

$$R_j = e_{1,j}A_1 + e_{2,j}A_2 + e_{3,j}A_3 \tag{1}$$

where R_j is the actual runoff in the j th month, $e_{n,j}$ is the calculated excess from C_n for the j th month, and A_n is the fraction of the catchment represented by capacity C_n . In practice, a modification of the approach is needed. The three partial areas must add to 1.0, but there is no constraint on the regression coefficients that they add to unity. In addition, regression analysis minimises a sum of squares of differences, and this gives too much weight to large values and too little weight to months with small amounts of runoff.

To overcome these problems, the procedure is modified as follows. Runoff always occurs from the smallest surface storage capacity before or at the same time as from the larger capacities. Using this information, the smallest capacity C_1 is found by trial and error testing of a single capacity for the whole catchment such that the occurrences of calculated surface runoff best match the occurrences of surface runoff in the actual record without concern for the amounts of calculated runoff. If C_1 is set too small, there will be too many calculated surface runoff events when no actual surface runoff occurred. If C_1 is set too large, there will be too many actual surface runoff events when there is no calculated surface.

Noting that $A_1 = 1.0 - A_2 - A_3$, Eq. (1) is rewritten as:

$$R_j = e_{1,j}(1.0 - A_2 - A_3) + e_{2,j}A_2 + e_{3,j}A_3 \tag{2}$$

that simplifies to:

$$(R_j - e_{1,j}) = (e_{2,j} - e_{1,j})A_2 + (e_{3,j} - e_{1,j})A_3 \tag{3}$$

C_1 is fixed to match the timings of surface runoff, which forces the calibration to match small events. A set of 30 possible values for C_2 and C_3 are selected in the plausible range between C_1 and an arbitrary upper

limit of 600 mm. Monthly values of runoff are calculated for C_1 and for each of the other capacities. The monthly values for C_1 are subtracted from the actual monthly values and from each of the calculated monthly values for the other 30 capacities. Eq. (3) is then solved for each combination of C_2 and C_3 and the pair with the highest multiple correlation coefficient is selected. The regression coefficients are the partial areas A_2 and A_3 , and $A_1 = 1.0 - A_2 - A_3$.

The data from the 16.8 ha catchment, shown in Fig. 7b, were used with the multiple linear regression method to compare the results with the graphical method. The results are compared in Table 1. Considering the small number of data points to fit the parameters, the agreement between the two methods is satisfying.

The multiple linear regression approach has been the main method of calibration of the AWBM since about 1995. Solving Eq. (3) for all combinations of the capacities takes about 1–2 s on a modern personal computer, and this speed of calculation allows the whole procedure to be simplified for ease of use. A default value of 10 mm is set for C_1 and the values of C_2 and C_3 and all partial areas are found. Daily runoff is calculated from the calibrated model and is shown plotted over actual daily flows on the PC screen. Visual comparison of actual and calculated surface runoff events is then used to decide if C_1 should be increased or decreased. The calculations are repeated with the new value of C_1 . The screen plot is also used to adjust the recession constants of surface runoff and baseflow. A complete calibration of the AWBM using this method usually takes just a few minutes.

3.3. Self-calibrating version AWBM2002

At the beginning of 2002, a self-calibrating version of the model, AWBM2002, was released for public use and made available on the CRCCH web site (see Section 1). The automatic calibration procedure was based on the results of applying the multiple linear regression calibration of the AWBM to many catchments over several years. By selecting a number of high quality data sets, i.e. with very high correlation between calculated and actual monthly values of runoff, it was found that the average value of surface storage capacity ($Ave = C_1A_1 + C_2A_2 + C_3A_3$) was far more important to calibration than the individual set of capacities and partial areas. An average pattern was found that could

be used to disaggregate an average capacity (Ave) into three capacities and three partial areas, as follows:

$$\text{Partial area of smallest store } A_1 = 0.134 \tag{4}$$

$$\text{Partial area of middle store } A_2 = 0.433 \tag{5}$$

$$\text{Partial area of largest store } A_3 = 0.433 \tag{6}$$

$$\begin{aligned} \text{Capacity of smallest store } C_1 &= 0.01 * Ave / A_1 \\ &= 0.075 * Ave \end{aligned} \tag{7}$$

$$\begin{aligned} \text{Capacity of middle store } C_2 &= 0.33 * Ave / A_2 \\ &= 0.762 * Ave \end{aligned} \tag{8}$$

$$\begin{aligned} \text{Capacity of largest store } C_3 &= 0.66 * Ave / A_3 \\ &= 1.524 * Ave \end{aligned} \tag{9}$$

Fig. 8 shows the average pattern based on an average capacity of 100 arbitrary units.

In operation, AWBM2002 assumes default values for the baseflow parameters, BFI and K_b , and the surface runoff recession constant K_s to make a preliminary calibration of the surface stores. There is provision in the program for a user to change the default values if wanted. The preliminary calibration of the surface storage parameters makes total calculated runoff equal to the total actual runoff. After this preliminary calibration, the BFI, K_b , and K_s are calibrated in that order and then again in the same order, using a measure of differences between calculated and actual daily flow hydrographs. The square root of the absolute difference between daily flows is summed over the period of calibration data with trial and error adjustment of the parameters to minimise the error function. In this way, the runoff generating parameters are calibrated against the amount of runoff and the parameters that affect the temporal pattern of runoff are calibrated against that pattern.

Table 1
Comparison of calibrations of capacities and partial areas

Method	C_1	C_2	C_3	A_1	A_2	A_3
Graphical	60	100	200	0.15	0.55	0.30
Regression	55	80	200	0.27	0.42	0.31

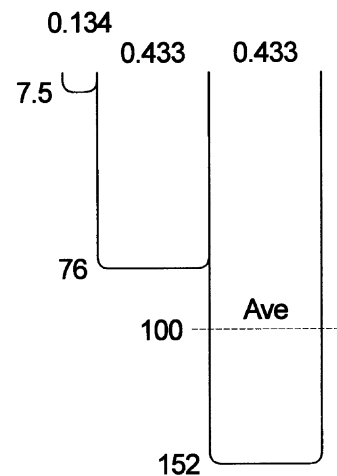

Fig. 8. Average pattern of surface storage based on 100 units of average storage.

3.4. Calibration for design flood estimation

The AWBM is used as a single model for water yield and water management studies without interaction with other models. When it is used in flood studies, it is used as the loss component model in association with a flood hydrograph model. In these circumstances, the AWBM is usually calibrated first so that estimates of rainfall excess are available for subsequent calibration of the hydrograph model. As a general principle, it is better to calibrate component models separately when this is possible to minimise the interactions between models in addition to the interactions among model parameters.

When the AWBM is used for water yield studies, the BFI can be evaluated using any of the established techniques for partitioning streamflow with sufficient accuracy for modelling daily and monthly flows. When the AWBM is used for design flood estimation, the calculated flood hydrographs are much more sensitive to the relative amount of surface runoff and baseflows during flood events. Table 2 illustrates the effect of change in the BFI on calibrated flood peaks. For each value of BFI, the AWBM was first calibrated, and then the WBMOD was calibrated, and flood peaks were extracted from the calculated streamflows.

Table 2 shows that it is desirable to check a range of values of BFI when the AWBM is used for design flood estimation.

4. Estimation of water yield

4.1. Data sets

Table 3 shows the hydrological characteristics of data sets for 19 catchments located across Australia. The catchment areas range in area from 0.9 to 3120 km²; runoff varies from 23 to 581 mm/year. The data sets cover a substantial range of the catchments encountered in engineering design work.

Table 2
Comparison of actual versus calculated peaks (m³/s) for a range of values of BFI—Boggy Creek catchment

Actual	Value of BFI				
	0.50	0.55	0.60	0.65	0.70
55.8	66.2	62.1	56.3	42.1	36.1
33.1	42.4	40.6	36.7	29.9	24.9
24.7	25.1	23.3	21.9	20.0	18.0
23.3	42.8	39.6	36.2	26.5	22.8
14.1	22.3	21.2	19.1	21.6	19.0
8.0	3.2	2.9	3.4	3.7	3.2
5.4	1.6	1.5	1.8	1.9	1.6
0.2	1.2	1.1	1.3	1.3	1.2

The evaporation data used in the water balance calculations were recorded Class A pan evaporation values. Each monthly value was divided by the days in the month to give daily values for the daily calculations.

4.2. Annual and monthly runoff

Most modern rainfall–runoff models will give good reproduction of average annual runoff and the runoff in individual years. For that reason, the main results presented here compare the reproduction of streamflows at monthly and daily intervals.

An initial comparison is made between the main regression method of calibration (Section 3.2) and the auto-calibration version of the AWBM (Section 3.3). Each of the catchments listed in Table 3 was calibrated twice, first using the multiple linear regression method and then using the auto-calibration method. After each calibration, calculated monthly values of runoff were related to actual monthly values using a linear regression forced through the origin, and a correlation coefficient was calculated. Fig. 9 shows a comparison of the correlation coefficients from the two methods of calibration.

In most cases, the auto-calibration performed almost as well as the more accurate multiple linear regression method. When the correlation coefficient from the auto-calibration is lower than that from the multiple linear regression calibration, the difference is mostly small. While the multiple linear regression remains the more accurate and preferred method of calibration, the auto-calibration method is very useful for preliminary analysis of new data and for quick scanning of a large number of data sets.

Fig. 9 also shows that the correlation coefficients based on monthly runoff are relatively high, with 18 of the 19 coefficients from the multiple linear regression calibration greater than 0.84. Five of the lowest coefficients are from catchments with the lowest average annual runoff, 23–54 mm/year. It is known from other studies that modelling of catchments with small annual runoff is more difficult than modelling catchments with much larger annual runoff.

Fig. 10 shows the plot of calculated versus actual monthly runoff in the 17 years of data from the 108 km² Boggy Creek catchment. Other studies of this catchment have shown that there is good correlation between calculated and actual runoff data.

4.3. Daily flows

A comparison of the frequency distributions of actual and calculated daily flows on the Boggy Creek catchment is shown in Fig. 11. The calculated results used in Fig. 11 are the same as those used in Fig. 10.

Table 3
Hydrological characteristics of catchments used in the study

G.S. No.	Stream	Station	Area (km ²)	Rain (mm/year)	Evap (mm/year)	Flow (mm/year)	No. of years
<i>Queensland</i>							
146001	Back Creek	Beechmont	7.0	1176	1036	367	3
138007	Mary River	Fishermans Pckt.	3120.0	1440	1223	581	4
<i>Victoria</i>							
415224	Avon River	Beazleys Bridge	259.0	539	1070	52	14
227219	Bass River	Loch	52.0	1108	889	340	10
403226	Boggy Creek	Angleside	108.0	1039	1132	290	17
406213	Campaspe River	Redesdale	629.0	768	1141	134	17
404207	Holland Creek	Kelfeera	451.0	966	1156	222	19
405237	Seven Creeks	Euroa Township	332.0	986	1138	254	20
227228	Tarwin River East Br	Mirboo	44.3	1162	996	349	9
<i>New South Wales</i>							
210022	Allyn River	Halton	205.0	1213	1210	377	8
412144	Cadiangullong Creek	Damsite	38.7	1173	1376	332	5
206001	Styx River	Jeogla	163.0	1319	1170	453	8
<i>South Australia</i>							
505517	North Para River	Penrice	118.0	520	1091	51	10
503504	Onkaparinga River	Houlgraves	321.0	859	1110	160	13
<i>Western Australia</i>							
615222	Dale River	Jelcobine	285.0	436	2033	23	20
609005	Weenup Creek	Mandelup Ck	87.0	481	1584	36	20
612010	Salmon Brk Trib	Wights Catchmnt	0.92	1160	1724	433	20
614196	Williams River	Saddleback Rd	1470.0	493	1709	47	20
610006	Wilyabrup Brk	Woodlands	82.0	1018	1099	303	20

The frequency distribution of calculated daily flows matches the distribution of actual flows very well with only minor underestimation in very high range. In this example, the daily flows were not optimised for specific matching of large daily flows, and some adjustment could be made to improve that aspect if needed.

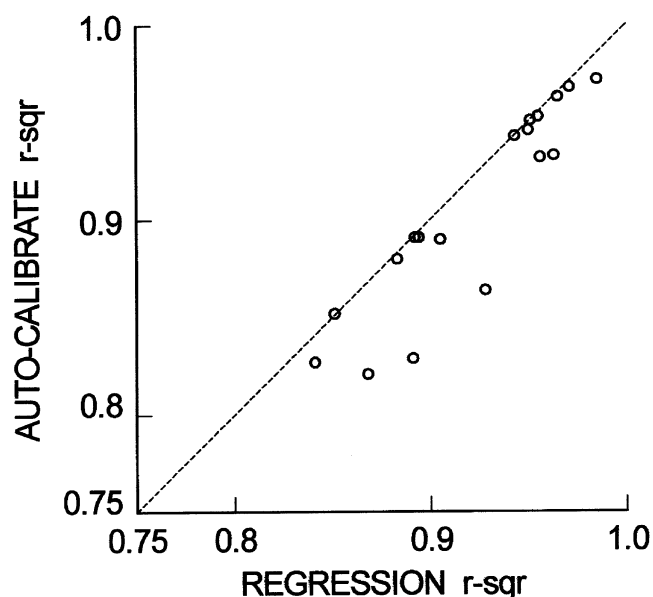

Fig. 9. Comparison of two methods of calibration.

The basic AWBM needs no modification for the calculation of daily flows for water yield or flood studies. In recent years, there has been increasing interest in very low flows and cease to flow periods for stream ecology management and because of increasing compe-

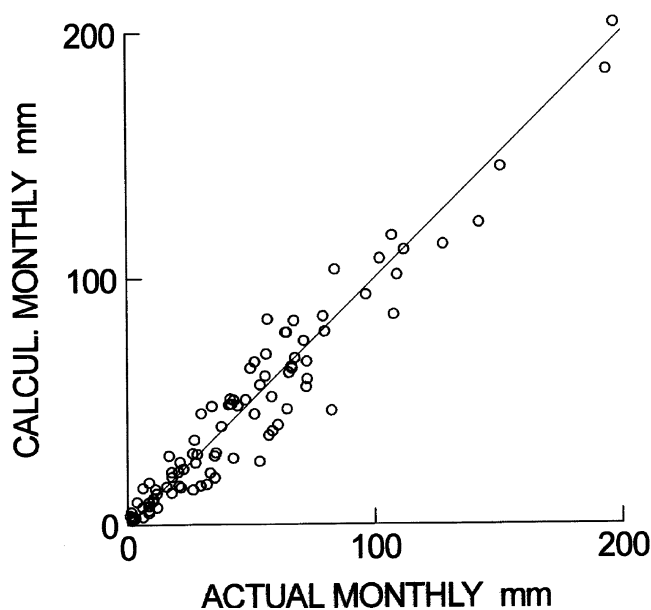

Fig. 10. Boggy Creek catchment—comparison of calculated and actual monthly runoff.

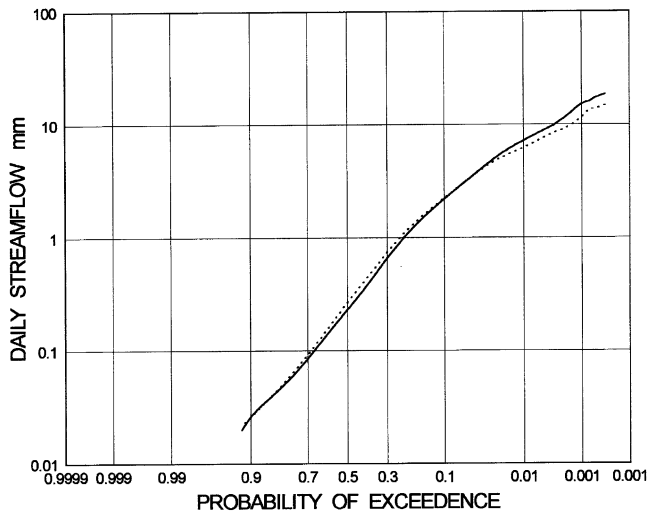

Fig. 11. Comparison of actual and calculated daily flows—Boggy Creek. Full line, actual; dotted line, calculated.

tition for water among riparian landholders. There are two aspects of modelling very low flows that need some elaboration—accuracy of flow data on computer files, and the effects of transmission loss.

The low range of actual daily flows in Fig. 11 is truncated because the computer file of actual runoff has values rounded to the nearest 0.01 mm. Below 0.03 mm, the distribution becomes obviously discontinuous and jumps to 0.02, then to 0.01 and then to zero. An accuracy of 0.01 mm/day amounts to only 0.3 mm/month, which is insignificant for both water yield and flood studies. If more accurate modelling of very low flows and cease-to-flow periods is needed, then more attention must be given to the precision of storage and handling of the flow data from actual measurement to final modelling use. The AWBM places no limits on the accuracy of input data or calculation other than that of the 16 bit or 32 bit hardware used.

Transmission loss is more widespread in Australian streams than might be expected from the lack of attention given to it in hydrological publications. The magnitude of the loss is relatively small in humid zone catchments and becomes relatively more significant in sub-humid, semi-arid and arid zone catchments. Its main effect on low flow analysis is to increase cease to flow periods. A version of the AWBM incorporating a transmission loss function was developed by the writer on contract for a specific application, and this worked well. It has not been incorporated into the main versions of the model for sake of simplicity; but the increasing interest in very low flows might dictate that another version of the AWBM specifically for low flow analysis, and incorporating a transmission loss function, be produced.

5. Design flood estimation

The AWBM has been used for design flood estimation in three distinct ways—in combination with a relationship of peak flow to daily volume to estimate flood peaks from annual maximum daily volumes, to convert rainfall to rainfall excess and use statistics of rainfall excess in lieu of rainfall statistics, and for continuous simulation of streamflow from which design flood hydrographs are directly extracted.

Boughton and Hill (1997) used a stochastic daily rainfall generation model to generate long sequences of daily rainfalls for input to the AWBM. A relationship between daily volumes and the associated peak flow rates was used to convert the frequency distribution of annual maxima daily volumes to the frequency distribution of annual maxima peak rates of runoff. They generated one million years of rainfall data, using estimates of probable maximum 24-h precipitation to calibrate the generation model, and used the output from the AWBM to estimate the frequency distribution of peak flows up to the probable maximum flood.

Heneker et al. (2002) used stochastic rainfall and evaporation input to the AWBM to produce a long sequence of rainfall excess. They developed rainfall excess frequency duration (REFD) curves to be used in lieu of rainfall intensity frequency duration (IFD) curves for design flood estimation. This eliminated the need for assumptions about losses, and allowed the common design flood estimation procedure based on IFD curves to be simply converted to the REFD curves. They reported “... the transformation from rainfall to rainfall excess appears similar for a number of catchments. This may lead to regionalisation”.

The continuous simulation system (CSS) for design flood estimation originated in CRCCH Research Project FL1.2 “Holistic approach to rainfall-based design flood estimation: continuous simulation approach”. The system includes the AWBM for continuous simulation of losses, and a non-linear runoff routing model (WBMOD) for hydrograph simulation at hourly time steps. A stochastic daily rainfall generation model and a daily to hourly disaggregation model enables the generation of long sequences of rainfall input to the system. Design flood statistics are extracted directly from the long sequences of calculated streamflows. Boughton et al. (1999) give a summary of the system. A more detailed description is available in the operating manual that is available with the software from the CRCCH web site (see Section 1).

Boughton et al. (2002) present the results of benchmark testing of the CSS with comparisons against other design flood estimation methods. Three catchments in Victoria, 62, 108 and 259 km² in area were used in the benchmark study. Table 4 shows the results

Table 4
Calibration of flood hydrographs—peak flows in m³/s

Avon		Boggy		Spring	
Observed	Calculated	Observed	Calculated	Observed	Calculated
116.4	118.9	55.8	59.4	37.6	32.6
110.9	111.3	33.1	38.2	25.7	22.1
92.2	84.2	24.7	23.4	22.8	26.2
65.4	102.9	23.3	38.0	22.2	19.0
63.7	64.0	14.1	20.3	20.1	10.4
59.6	56.5	8.0	2.8	19.3	16.0
49.1	56.5	5.4	1.6	14.9	22.2
		0.2	1.0		

of reproducing the peaks of flood events available for calibration from each of the catchments.

Fig. 12 shows the results of reproducing the largest available flood hydrograph in each data set. These data sets are available as test data with the system software on the CRCCH web site.

Newton and Walton (2000) report results of another study, again comparing the CSS results with those from two other design flood estimation methods. Droop and Boughton (2002) replaced the WBMOD flood hydrograph model in the CSS with a well-established runoff routing model, WBNM, and compared the results. The AWBM was used as the continuous simulation loss model in each case.

6. Estimating runoff from ungauged catchments

When the average annual rainfall and runoff data in Table 3 were plotted, it was found that there was a general relationship that could be used to estimate average annual runoff from average annual rainfall. This relationship is shown in Fig. 13, where the circles show the data from Table 3.

In the first instance, the relationship was thought to be singular, however, it was soon obvious that provision was needed to accommodate a range of rainfall–

runoff relationships. For these reasons, a “catchment characteristic” (RC) was introduced to allow for different runoff characteristics in different regions, land use (e.g. urbanization) and the effects of vegetative cover. Three values of the runoff characteristic, 3.0, 5.0 and 7.0, are illustrated in Fig. 13.

The rainfall–runoff relationships shown in Fig. 13 for a given runoff characteristic are based on the hyperbolic tangent function introduced by Boughton (1966). Each relationship has a minimum annual rainfall (Min) below which no runoff occurs. In the higher rainfall range, the relationship becomes asymptotic to a 45° line originating at a rainfall (Asy) on the x-axis. Given an average annual rainfall (Rain) and a runoff characteristic (RC), the average annual runoff (Runoff) is calculated in the following steps.

$$\text{Min} = 300 - 60 \cdot \text{RC} \tag{10}$$

$$\text{Asy} = 1950 - 200 \cdot \text{RC} \tag{11}$$

$$x = (\text{Rain} - \text{Min}) / (\text{Asy} - \text{Min}) \tag{12}$$

$$\text{Tanh} = (\exp(x) - \exp(-x)) / (\exp(x) + \exp(-x)) \tag{13}$$

$$\text{Runoff} = (\text{Rain} - \text{Min}) - (\text{Asy} - \text{Min}) \cdot \text{Tanh} \tag{14}$$

Two versions of the AWBM are available for use on ungauged catchments. One version is used with rainfall and evaporation data and a specified value of the runoff characteristic to estimate runoff from an ungauged catchment. The other version self-calibrates to rainfall and runoff data on a gauged catchment and determines a value of the runoff characteristic for that catchment. The latter version allows for objective determination of the runoff characteristic from gauged catchments for use on ungauged catchments.

In the future, it is probable that accumulated data will allow the effects of land use and management to be modelled through the use of different values of the runoff characteristic. For example, there are relationships emerging for differences in runoff from forest and grass cover (Vertessy, 1999) and such information can be

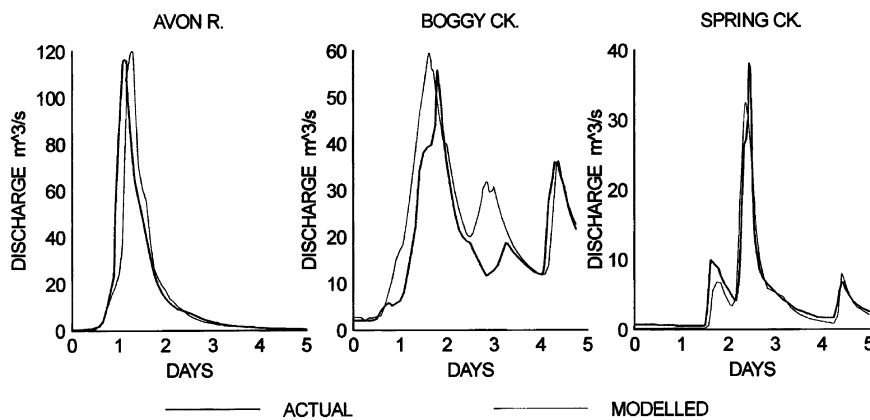

Fig. 12. Comparison of actual and modelled largest hydrograph on each catchment.

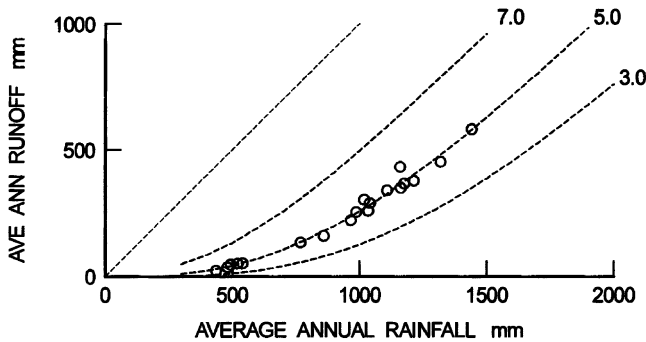

Fig. 13. Variation in runoff due to runoff characteristic. Circles show data from Table 1.

incorporated into the UGAWBM3 framework when available.

7. Comparisons with other models

Comparative studies of different rainfall–runoff models are relatively rare considering the profusion of models and the abundant literature on other aspects of catchment modelling. There have been four studies in which the AWBM has been directly compared with other models, namely the SFB model, the USDA SCS curve number method, the PDSMM, and an auto-regressive mathematical model.

Sharifi and Boyd (1994) compared the SFB and AWBM using 12 years of daily data from an 8 km² catchment in New South Wales. When the AWBM became available in 1993, the SFB was the daily water balance model in most common use in Australia (Boughton, 1988), and was the main model later replaced by the AWBM. The comparison was made at the beginning of a PhD project, and Sharifi (1996) subsequently used the AWBM for that project.

Boughton (1995) compared the AWBM and the curve number method on two catchment, one a 16.8 ha agricultural scale catchment with only surface runoff, and the other a 156 km² catchment with baseflow. The comparison of results was subjective with no objective evaluation, but the results generally favoured the AWBM.

Muncaster et al. (1997) compared the AWBM and PDSMM at hourly time steps as loss models in a study of continuous hydrologic modelling for design flood estimation. The study was part of an M. Eng. Sci. project (Muncaster, 1998) at Monash University as well as part of Research Project FL1.2 “Holistic approach to rainfall-based design flood estimation: continuous simulation approach” of the CRCCH at Monash University. The results presented by Muncaster et al. (1997) favour the AWBM over the PDSMM. The main CSS for design flood estimation that emerged from Project FL1.2 was based on the AWBM (Boughton et al., 1999, 2002; Boughton and Droop, 2003).

Metcalf et al. (2002) compared the AWBM with an auto-regressive model on the 108 km² Boggy Creek catchment in Victoria. The comparison used daily data and was based on reproduction of several statistics of daily flow. There were several versions of the auto-regressive model tested, but the results favoured the AWBM. The authors reported “The ... (AWBM) ... performed very well for the Australian catchment Boggy Creek. This approach gave the best approximation of the frequency distribution of marginal flows”.

8. Conclusions

The AWBM has been part of two PhD projects (Sharifi, 1996; Heneker, 2002), three Masters projects (Kazazic, 1996; Muncaster, 1998; James-Smith, 2002), an Honours project (Cakers and Yu, 1998) and a Civil Engineering final year project (Cheung and Yu, 1999). It is used for undergraduate teaching of catchment modelling to Civil Engineering students in several Australian universities. It has been used in two substantial research project of the CRCCH. It is being incorporated into the Interactive Component Modelling System of the CRCCH, which is a toolkit of different types of models and decision support systems, intended for use by catchment and water resource managers. It is in widespread use for routine engineering design in Australia.

There are several reasons for the general acceptance and use of the AWBM in Australia. The software and operating manual have been freely available since its development, and the ready availability for downloading from the web site of the CRCCH has assisted in its spread. The model-specific calibration methods, combined with user-friendly graphical presentation on PC screens, made the model easier to use than contemporary alternatives. This was supplemented by a series of training workshops to give new users background information about the model as well as instructions in its use.

The different versions of the model for water yield and flood studies, currently freely available on the CRCCH web site, each have an operating manual and several test data sets ready for use. The version of the AWBM for use on ungauged catchments is available directly from the writer. The availability of test data sets with the software makes it possible for a potential user to quickly assess the capability of the model(s) for the intended purpose(s).

Although a few minor modifications of the model structure have been tried in individual studies, there have been no significant change made to the basic structure of the AWBM since its development. Up to the end of the 1990s, most use of the AWBM was for daily water balance modelling for water yield and water management studies. In the future, the bigger application is likely to be as a continuous simulation

loss model for design flood estimation. One current development is extension from the present lumped input to distributed rainfall input, particularly for distributed flood hydrograph modelling. It seems likely that the AWBM will be a significant part of Australian catchment hydrology for some time to come.

Acknowledgements

I acknowledge with thanks the assistance given by the Cooperative Research Centre for Catchment Hydrology in making the AWBM suites of software available for free downloading on their web site at <http://www.catchment.crc.org.au/models>. This ready access to the models, operating manuals and test data sets has contributed substantially to the transfer of the AWBM technology from the research domain into practical use.

References

- Boughton, W.C., 1966. A mathematical model for relating runoff to rainfall with daily data. *Civil Eng. Trans. Inst. Eng. Aust.* CE8 (1), 83–93.
- Boughton, W.C., 1987. Evaluating partial areas of watershed runoff. *ASCE J. Irrig. Drain. Eng.* 113 (3), 356–366.
- Boughton, W.C., 1988. Modelling the rainfall–runoff process at the catchment scale. *Civil Eng. Trans. Inst. Eng. Aust.* CE30 (4), 153–162.
- Boughton, W.C., 1989. A review of the USDA SCS curve number method. *Aust. J. Soil Res.* 27, 511–523.
- Boughton, W.C., 1990. Systematic procedure for evaluating partial areas of watershed runoff. *ASCE J. Irrig. Drain. Eng.* 116 (1), 83–98.
- Boughton, W.C., 1993a. A hydrograph-based model for estimating the water yield of ungauged catchments. In: *Proceedings of the 1993 Hydrology and Water Resources Conference*, Institution of Engineers, Australia, National Conference Publication no. 93/14, pp. 317–324.
- Boughton, W.C., 1993b. Direct evaluation of parameters in a rainfall–runoff model. In: McAleer, M., Jakeman, A. (Eds.), *Proceedings of the International Congress on Modelling and Simulation*, vol. 1. Modelling and Simulation Society of Australia, pp. 13–18.
- Boughton, W.C., 1995. An Australian water balance model for semi-arid watersheds. *J. Soil Water Conser.* 50 (5), 454–457.
- Boughton, W.C., 2001. A continuous simulation system for design flood estimation—operating manual version 2.0 January 2001. Unpublished Report, 45 pp. Available as a computer file with system software from www.catchment.crc.org.au.
- Boughton, W.C., 2002. AWBM catchment water balance model: calibration and operation manual version 4.0. Unpublished Report, 40 pp. Available as a computer file with system software from www.catchment.crc.org.au.
- Boughton, W.C., Carroll, D.G., 1993. A simple combined water balance/flood hydrograph model. In: *Proceedings of the 1993 Hydrology and Water Resources Conference*, Institution of Engineers, Australia, National Conference Publication no. 93/14, pp. 299–304.
- Boughton, W.C., Droop, O., 2003. Continuous simulation for design flood estimation—a review. *Environ. Model. Software* 18 (4), 309–318.
- Boughton, W.C., Hill, P., 1997. A design flood estimation system using data generation and a daily water balance model. CRC for Catchment Hydrology, Report 97/8, Monash University, Melbourne.
- Boughton, W.C., Muncaster, S.H., Srikanthan, R., Weinmann, P.E., Mein, R.G., 1999. Continuous simulation for design flood estimation—a workable approach. In: *Proceedings of the WATER99 Joint Congress*, Brisbane, 6–8 July, I.E.Aust, Canberra, pp. 178–183.
- Boughton, W., Srikanthan, S., Weinmann, E., 2002. Benchmarking a new design flood estimation system. *Aust. J. Water Resour. Inst. Eng. Aust.* 6 (1), 45–52.
- Cakers, U., Yu, B., 1998. Using a water balance model—AWBM—to assess likely hydrological response to a significant decrease of rainfall in south-west Western Australia. *Aust. J. Water Resour.* 2 (2), 67–75.
- Chapman, T., 1999. A comparison of algorithms for stream flow recession and baseflow separation. *Hydrol. Proces.* 13, 701–704.
- Cheung, L., Yu, B., 1999. Three conceptual stores in AWBM. Are they really necessary? In: *Proceedings of the Water99 Joint Congress*, Institution of Engineers, Australia, vol. 2, pp. 993–998.
- Droop, O., Boughton, W., 2002. Integration of WBNM into a continuous simulation system for design flood estimation. *Research Report 2/02*, Gilbert & Associates, Brisbane.
- Evans, J.P., Jakeman, A.J., 1998. Development of a simple catchment-scale rainfall–evapotranspiration–runoff model. *Environ. Model. Software* 13 (3–4), 385–393.
- Heneker, T.M., 2002. An improved engineering design flood estimation technique: removing the need to estimate initial loss. PhD Thesis, Department of Civil and Environmental Engineering, University of Adelaide.
- Heneker, T.M., Lambert, M., Kuczera, G., 2002. Overcoming the joint probability problem associated with initial loss estimation in design flood estimation. In: *Proceedings of the 27th Hydrology and Water Resources Symposium*, Institution of Engineers, Australia, Canberra.
- James-Smith, J., 2002. Development of a water management model for evaluation of streamflow for aquifer storage and recovery. M. Eng. Sci. Thesis, Department of Civil and Environmental Engineering, University of Adelaide.
- Kazacic, E., 1996. Use of daily rainfall and flow data to extend the instantaneous peak flow series. M. Eng. Sci. Thesis, Department of Civil Engineering, Monash University.
- Klaassen, B., Pilgrim, D.H., 1975. Hydrograph recession constants for New South Wales streams. *Civ. Eng. Trans. I.E.Aust.* CE17 (1), 43–49.
- Kohler, M.A., Linsley, R.K., 1951. Predicting the runoff from storm rainfall. *US Weather Bureau Research Paper* 34.
- Kohler, M.A., Richards, M.M., 1962. Multicapacity basin accounting for predicting runoff from storm precipitation. *Jour. Geophys. Res.* 67 (13), 5187–5197.
- Metcalfe, A., Heneker, T.M., Lambert, M.F., Kuczera, G., Itan, I., 2002. A comparison of models for catchment runoff. In: *Proceedings of the 27th Hydrology and Water Resources Symposium*, Institution of Engineers, Australia.
- Moore, R.J., 1985. The probability-distributed principle and runoff production at a point and basin scales. *Hydrol. Sci. J.* 30 (2), 273–297.
- Muncaster, S.H., Weinmann, P.E., Mein, R.G., 1997. An application of continuous hydrologic modelling to design flood estimation. In: *Proceedings of the 24th Hydrology and Water Resources Symposium held at Auckland*, New Zealand. Institution of Engineers, Australia, Canberra.
- Muncaster, S., 1998. The potential of continuous hydrologic modelling for design flood estimation. M. Eng. Sci. Thesis, Monash University, Melbourne.
- Newton, D., Walton, R., 2000. Continuous simulation for design flood estimation in the Moore River catchment, Western Aus-

- tralia. In: *Proceeding of the Hydrology and Water Resources Symposium*, vol. 1. Institution of Engineers, Australia, Canberra.
- Rallison, R.E., 1980. Origin and evolution of the SCS runoff equation. In: *Symposium on Watershed Management 1980*, vol. II. ASCE, New York, pp. 912–924.
- Sharifi, F., 1996. Catchment rainfall–runoff computer modelling. PhD Thesis, University of Wollongong.
- Sharifi, F., Boyd, M.J., 1994. A comparison of the SFB and AWBM rainfall–runoff models. In: *Proceedings of the Water Down Under Conference*, Institution Engineers Australia, vol. 3, pp. 491–494.
- Steenhuis, T.S., Winchell, M., Rossing, J., Zollweg, J.A., Walter, M.F., 1995. SCS runoff equation revisited for variable-source runoff areas. *J. Irrig. Drain. Eng. ASCE* 121 (3), 234–238.
- Vertessy, R.A., 1999. The impacts of forestry on streamflows: a review. *Forest Management for Water Quality and Quantity*, CRC for Catchment Hydrology, Report 99/6, pp. 93–109.
- Wheater, H.S., Jakeman, A.J., Beven, K.J., 1993. Progress and directions in rainfall–runoff modelling. In: Jakeman, A.K., Beck, M.B., McAleer, M.J. (Eds.), *Modelling Change in Environmental Systems*. John Wiley & Sons Ltd.